

TURBAIR® Blower

Type RT

Application

Dewatering under vacuum

Features

- High reliability
- High thermal efficiency
- Wide performance & operational range
- Environmentally friendly
- Low space requirement
- No seal water consumption
- Specially suited for felt conditioning
- Specially suited for tissue applications

internal, steplessly adjustable diffuser blades ensure variable volume flows at constant vacuum and optimum efficiency.

The air exits the blower with a temperature of approximately 140 °C. This thermal energy can be recuperated in a heat exchanger and can be used for preheating the process water, as energy for the drying process, room heating, etc.

Control system

Three fully automatic control loops ensure operational safety and reliability.

■ Overload protection

Throttle valves in the suction duct close, simulating the flow resistance of the missing paper sheet, thus preventing air inrush and drive motor overload.

■ Antisurge protection

When operated below minimum flow level, the blower will surge. To avoid this, an automatic valve bleeds air into the suction branch until stable operation is restored.



Type RT 71

■ Power control

The automatic blower control adjusts to varying air flows. A pneumatic servomotor opens the diffuser blades with increasing volume flow and closes them with reduced flow.

Design

The spiral casing with horizontal intake flanges is coupled directly to the spur gear casing or mounted directly on the base frame. The stepless adjustable diffuser blades, together with the pneumatic servodrive motor, are integrated in the spiral casing.

The welded base frame with foundation pads and fixation bolts has an integrated oil reservoir. All oil system and electric motor auxiliaries are mounted on the base frame.



Operation

The RT single-stage blower is driven via a gear box by an electric motor with constant or variable speed. The air/water mix aspirated from the paper machine is collected in a separator where water, particles and fibers solids are removed. The air is then ducted into the impeller and compressed. The blower's

TURBAIR® Vacuum Systems

Engineering the Future – since 1758.

MAN Diesel & Turbo



Dimensions

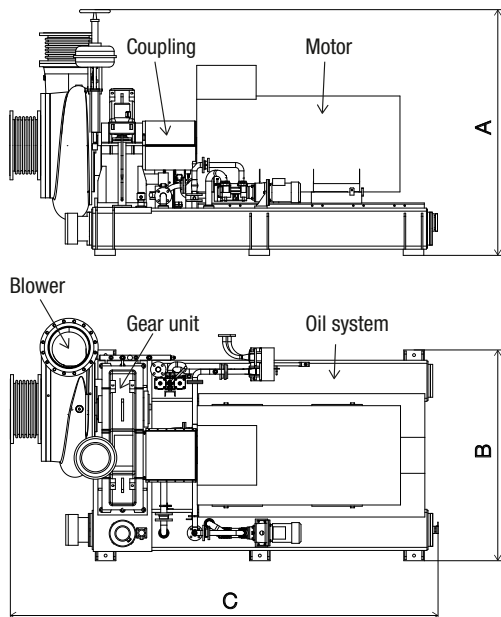

Type RT 71

RT Type	Height/width/length [mm]		
	A	B	C
56	2,350	2,190	3,360
71	2,600	2,715	4,310
90	2,990	3,165	5,200

Characteristics and operating data

RT single-stage blowers are exceptionally suitable for felt conditioning thanks to their ability to adjust power and volume flow to the changing felt permeability while, at the same time, maintaining optimum efficiency. The constant dewatering level results in optimum conditioning with a corresponding extension of the felt lifetime.

RT Type	Air flow [m ³ /min]	Weight [kg]
56	200 – 800	7,100
71	400 – 1,500	11,000
90	600 – 2,200	18,500

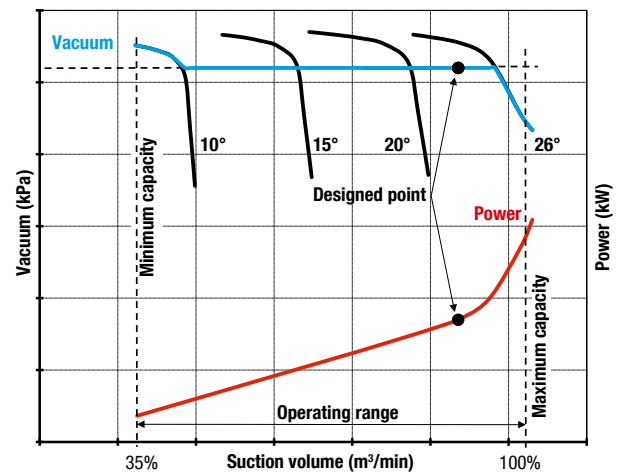

Lubricating oil system

All the gear box journal bearings are pressure-lubricated. During start-up and shutdown, an electronically driven auxiliary oil pump provides lubrication to the bearings. Upon reaching nominal speed, a mechanically driven lube oil pump connected to the gearbox casing takes over the oil supply. During normal operation, the electrically driven pump serves as stand-by. Practice has shown that this arrangement offers the best possible blower availability.

MAN Diesel & Turbo Schweiz AG

TURBAIR® Vacuum Systems

Hardstrasse 319

8005 Zürich, Switzerland

Phone +41 44 278-2211

Fax +41 44 278-2261

www.mandieselturbo.com

All data provided in this document is nonbinding. This data serves informational purposes only and is especially not guaranteed in any way. Depending on the subsequent specific individual projects, the relevant data may be subject to changes and will be assessed and determined individually for each project. This will depend on the particular characteristics of each individual project, especially specific site and operational conditions.